

Sample Gas Cooler EGK 1SD



Accurate measurements of gases require gas samples with stable dew points even under harsh ambient conditions.

The EGK models provide a compressor-type cooling system connected to a cooling block. The cooling block evenly dissipates the heat thus supporting the highly efficient heat exchangers. The temperature of the cooling block is regulated by the **Bühler Constant Regulating System**. This system allows smooth regulation and eliminates the disadvantages of the traditional on-off operating mode.

The EGK 1 SD has an internal display showing the cooling block temperature which blinks with status alarm (± 5 °F deviation of the preset temperature). In both models, a dry relay contact is built in for status monitoring.

The cooling block accommodates either a single stream or a dual stream heat exchanger hence the cooler may serve two separate sample gas streams.

Condensate is removed either by peristaltic pumps, by automatic condensate drains or condensate vessels.

- **Compact design**
- **Single or dual gas streams**
- **Heat exchangers made of stainless steel, Duran glass or PVDF**
- **Bühler Constant Regulating System**
- **Cooling block temperature display**
- **Self-checking**
- **Status alarm**
- **Nominal cooling capacity 320 kJ/h**
- **Dew point stability 0.1 °C**
- **CFC-free**
- **FM approval**

Technical Data

Ready for operation	max. 15 minutes
Cooling capacity (at 77°F)	300 Btu/hr
Ambient temperature	40-120 °F
Dew point (set at factory)	approx. 40 °F
Dew point variations static	0.1 K
Over full operation range	± 1.5 K
Power supply	115 V or 230 V, 50/60 Hz, Plug DIN 43650
Power consumption	290/260 VA, fuse (external) 10 A
Alarm output	max. 250 V, 2 A, 50 VA Plug DIN 43650
Protection class	IP 20
Housing	Stainless steel
Installation	Table or wall mounting
Packing dimensions	approx. 15.5 x 12 x 16 inches
Weight incl. heat exchangers	approx. 33 lb.
FM File-No.	3040918

Dimensions (in)

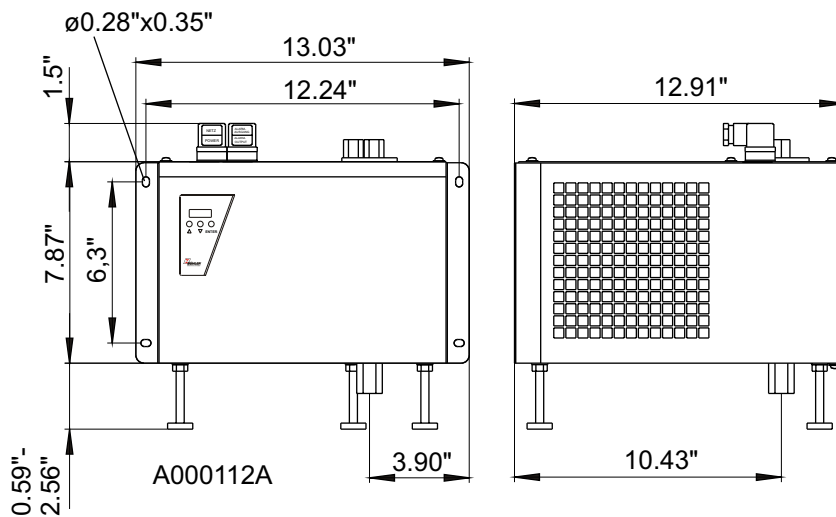

Typical Installation Diagram:

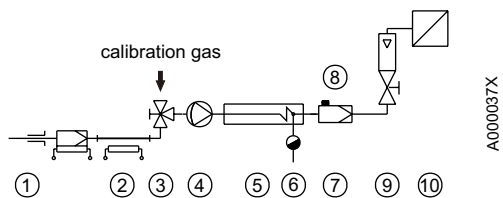

- 1 Sample probe
- 2 Sample tube
- 3 3 way valve
- 4 Sample gas pump
- 5 Sample gas cooler EGK 1SD
- 6 Automatic condensate drain or peristaltic pump
- 7 Fine filter
- 8 Moisture detector
- 9 Flow meter
- 10 Analyser

For models and specs of components see individual data sheets.

Heat Exchanger

The energy content of the sample gas and, as a result, the required cooling capacity of the gas cooler is determined by 3 parameters: gas temperature ϑ_G , dewpoint τ_e (moisture content) and flow v . The outlet dew point rises with increasing energy content (heat) of the gas. The required cooling capacity is determined by the maximum acceptable level of the outlet dew point.

The following table shows cooler performance assuming the following conditions: $\tau_e=120^\circ\text{F}$ and $\vartheta_G=160^\circ\text{F}$. Indicated is the v_{max} in lpm cooled air (i.e. after the moisture has condensed). If the actual values stay below the parameters τ_e and ϑ_G , v_{max} can be increased. For example (TG), instead of $\tau_e=120^\circ\text{F}$, $\vartheta_G=160^\circ\text{F}$ and $v=5.7$ lpm the values $\tau_e=105^\circ\text{F}$, $\vartheta_G=160^\circ\text{F}$ a maximum flow rate of $v=7.1$ lpm could be achieved.

Please contact one of Buhler's application specialists for assistance and further information.

Heat Exchanger	TS TS-I ²⁾	TG	TV-SS TV-I ²⁾	DTS (DTS-6 ³⁾) DTS-I (DTS-6-I ³⁾) ²⁾	DTG	DTV ³⁾ DTV-I ^{2) 3)}
Flow rate v_{max} ¹⁾	8.3 lpm	6.7 lpm	3.9 lpm	2 x 4.2 lpm	2 x 3.3 lpm	2 x 2.7 lpm
Inlet dew point $\tau_{e,\text{max}}$ ¹⁾	175 °F	175 °F	150 °F	175 °F	150 °F	150 °F
Gas inlet temperature. $\vartheta_{G,\text{max}}$ ¹⁾	355 °F	285 °F	285 °F	355 °F	285 °F	285 °F
Max. cooling capacity Q_{max}	427 Btu/hr	218 Btu/hr	114 Btu/hr	427 Btu/hr	218 Btu/hr	175 Btu/hr
Gas pressure p_{max}	2321 psig	44 psig	44 psig	363 psig	44 psig	29 psig
Pressure drop Δp ($v=2.5$ lpm)	0.12 psig	0.12 psig	0.12 psig	each 0.07 psig	each 0.07 psig	each 0.22 psig
Dead volume V_{tot}	4.2 cu. in.	2.9 cu. in.	7.9 cu. in.	1.7 / 1.5 cu. in.	1.7 / 1.5 cu. in.	1.3 / 1.3 cu. in.
Sample gas connections (metric)	G 1/4"	GL 14 (0.2 in.) ⁴⁾	DN 4/6	tube 0.2 in.	GL 14 (0.2 in.) ⁴⁾	DN 4/6
(US)	NPT 1/4"	GL 14 (1/4") ⁴⁾	1/4"-1/6"	tube 1/4"	GL 14 (1/4") ⁴⁾	1/4"-1/6"
Condensate outlet connections (metric)	G 3/8"	GL 25 (0.5 in.) ⁴⁾	G 3/8"	tube 0.4 in. (0.2 in.)	GL 18 (0.4 in.) ⁴⁾	DN 5/8
(US)	NPT 3/8"	GL 25 (1/2") ⁴⁾	NPT 3/8"	tube 3/8" (1/4")	GL 18 (3/8") ⁴⁾	3/16"-5/16"

¹⁾ Max. cooling capacity of the cooler must be considered

²⁾ Types marked "I" have NPT-threads or US tubes, respectively

³⁾ Can only be used with peristaltic pumps

⁴⁾ Inner diameter gasket

Performance Data

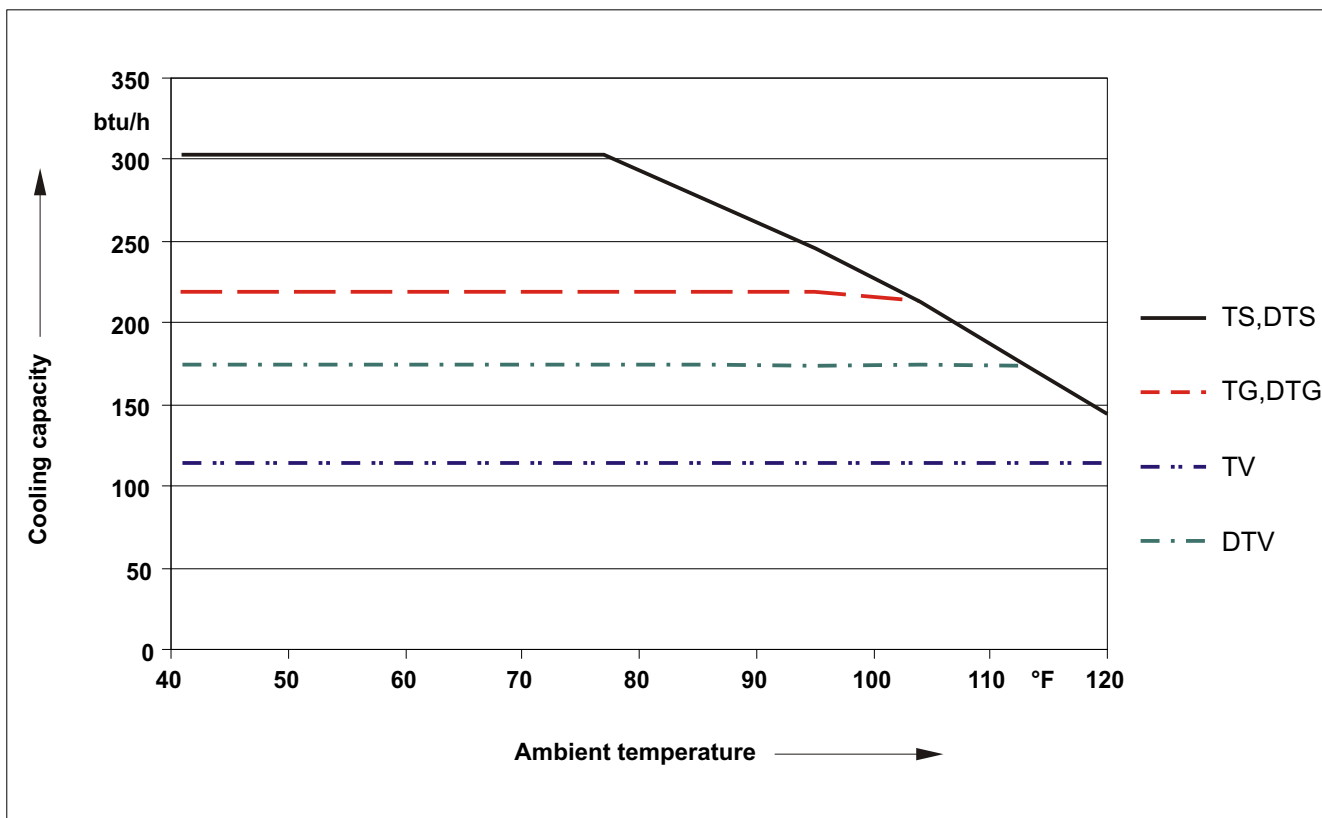

Please indicate with order

Please extract the part number from the type designation code below.

Please note: Each gas path should be equipped with a peristaltic pump or an automatic condensate drain.

Part no.	4	5	6	1				0	0	0	0	EGK 1SD with display
Mains voltage												
	1											115V metric fittings
	2											230V metric fittings
	3											115V US fittings
	4											230V US fittings
Gas path / Material / Version												
		0	0	0								without heat exchanger
		1	1	0								1 gas path / single path heat exchanger stainless steel / (TS or TS-I)
		1	2	0								1 gas path / single path heat exchanger glass / (TG)
		1	3	0								1 gas path / single path heat exchanger PVDF / (TV-SS or TV-I)
		2	6	0								2 gas paths / dual path heat exchanger stainless steel / (DTS or DTS-I)
		2	6	1								2 gas paths / dual path heat exchanger stainless steel / (DTS-6 or DTS-6-I) ¹⁾
		2	7	0								2 gas paths / dual path heat exchanger glass / (DTG)
		2	8	0								2 gas paths / dual path heat exchanger PVDF / (DTV or DTV-I) ¹⁾
Condensate Drain ²⁾												

¹⁾ Condensate outlet only suitable for peristaltic pumps

²⁾ Peristaltic pumps for separate mounting available

Accessories

Part No.	Description
441 00 01	Automatic condensate drain 11 LD V 38
441 00 04	Automatic condensate drain AK 20, PVDF
441 00 05	Condensate vessel GL 1; glass, 0,4 l
441 00 19	Condensate vessel GL 2; glass, 1 l
912 40 30 104	Peristaltic pump 230 V, 0,3 l/h, separate mounting
912 40 30 105	Peristaltic pump 115 V, 0,3 l/h, separate mounting