

# Gas Analyzer for IR-Sensitive Gases and Oxygen

## BA 5000



The BA 5000 gas analyzer can measure up to 4 gas components. The instrument can be configured a maximum of three infrared gases such as CO, CO<sub>2</sub>, NO, SO<sub>2</sub>, or CH<sub>4</sub> plus the measurement of O<sub>2</sub> with an electrochemical fuel cell.

The analyzer can be used in emission measurement systems and for process and safety monitoring.

- **19" rack mount or portable configurations available**
- **Simple, fast user programming**
- **Calibration with cal gas is only necessary every 6 to 12 months, depending on application**
- **Large, backlit LCD**
- **Two measurement ranges per gas component**
- **Automatic correction atmospheric pressure variations**
- **Low-flow alarm**
- **Maintenance request alert**
- **Three binary inputs**
- **Eight relay outputs**
- **Four potential-free analog outputs 4-20mA**
- **RS 485**

## Application Examples

- Optimization of combustion systems
- Monitoring of exhaust gas concentration from combustion systems with all types of fuel (oil, gas and coal) as well as operational measurements for thermal incineration plants
- Room air monitoring
- Monitoring of air in fruit stores, greenhouses, fermenting cellars and warehouses
- Monitoring of process control functions
- Heat treating

Two independent, selective measurement principles are used in the BA 5000.

## Infrared Measurement

This spectroscopic method is based on the absorption of non-dispersive IR radiation. The attenuation in the radiation of specific wavelengths is a measure of the respective concentration of the gas.

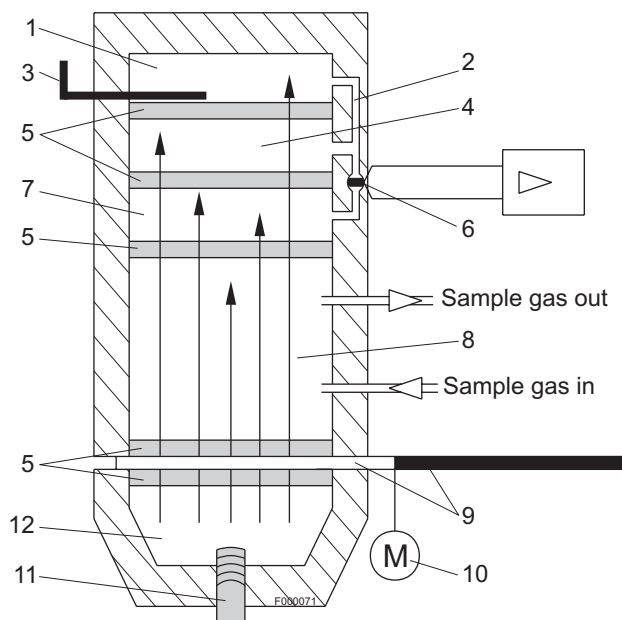

- |    |                       |
|----|-----------------------|
| 1  | Third detector layer  |
| 2  | Capillary             |
| 3  | Slide                 |
| 4  | Second detector layer |
| 5  | Windows               |
| 6  | Microflow sensor      |
| 7  | First detector layer  |
| 8  | Sample bell           |
| 9  | Chopper               |
| 10 | Synchronous motor     |
| 11 | IR source             |
| 12 | Reflector             |

## Oxygen Measurement

The oxygen sensor operates according to the principle of a fuel cell. The oxygen is converted at the boundary layer between the cathode and electrolyte; the resulting current is proportional to the concentration of oxygen.

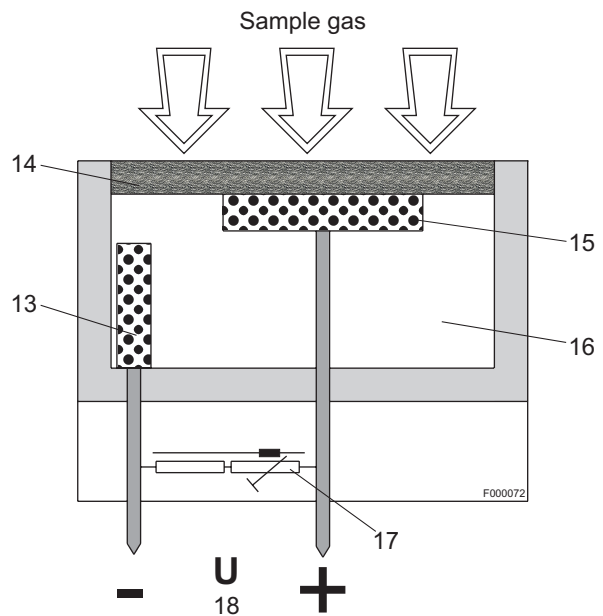

- |    |   |
|----|---|
| 13 | Lead anode  |
| 14 | Oxygen diffusion membrane made of FEP                     |
| 15 | Gold cathode  |
| 16 | Electrolyte (acetic acid)                                 |
| 17 | Thermistor and load resistor for temperature compensation |
| 18 | Signal output   |

## General Technical Data

Measured components	max. 4 of which up to 3 may be infrared-sensitive gases plus oxygen
Analog outputs	max. 4, floating, 0 / 2 / 4 to 20 mA, linearized
Load	≤750 Ω
Characteristics	linearized
Membrane keypad	LCD with LED backlighting and contrast control, function keys
Display	80 characters (4 lines / 20 characters)
EMC interference immunity	according to standard requirements of NAMUR NE21 (05/93) or EN 50081-1, EN 50082-2, EN 61010
Position of use	front panel vertical
Relay outputs	8, e.g. for fault, maintenance request, limit, function check, AC/DC 24 V / 1 A
Binary inputs	3, floating for pump on/off, AUTOCAL trigger and synchronization
Serial interface	RS 485
Warm-up time	approx. 5 min. max. accuracy is achieved after approx. 45 minutes
AUTOCAL function	automatic analyzer calibration with ambient air, cycle time adjustable from 1 to 24 hours

## Dimensions

Portable analyzer	(H x W x D) 170 mm x 465 mm x 392mm (6.7 x 18.3 x 15.4 in)
frame19", 4 HU	177 mm x 483 mm x 360 mm (7.0 x 19.0 x 14.2 in)

Weight	approx. 22 lb
Degree of protection	IP 21 (EN 60529)

## Power supply

Power supply	AC 100 V, + 10% / - 15%, 50 Hz AC 200 V, + 10% / - 15%, 50 Hz AC 230 V, + 10% / - 15%, 50 Hz AC 100 V, + 10% / - 15%, 60 Hz AC 120 V, + 10% / - 15%, 60 Hz AC 230 V, + 10% / - 15%, 60 Hz
Power consumption	approx. 50 VA

## Gas input conditions

Sample gas pressure	7.3 to 22 psig absolute
Sample gas flow	66 to 120 l/h (1.1 to 2 l/min.)
Sample gas temperature	32 to 120 °F
Sample gas humidity	< 90% RH <sup>1)</sup> or dependent on measurement task

## Ambient conditions

Permissible ambient Temperature	
Operation	40 to 115 °F
Storage and transport	-5 to 140 °F
Permissible ambient humidity	<90% RH <sup>1)</sup> for storage and transport
Permissible pressure variations	20 to 35 in. Hg

<sup>1)</sup>RH: relative humidity

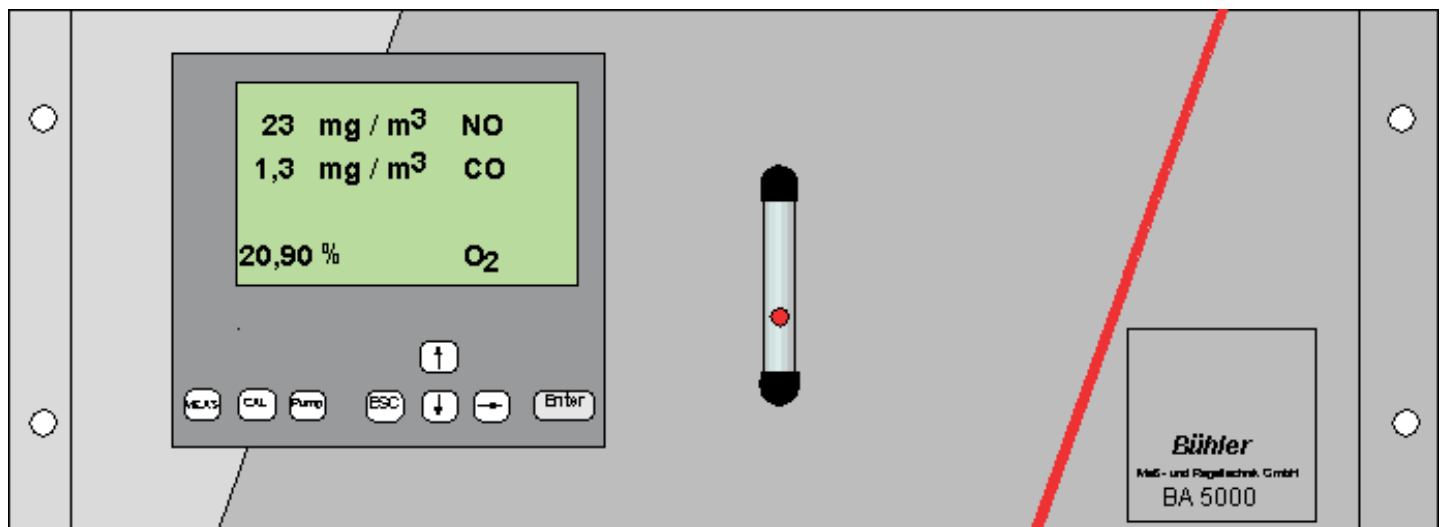

## Technical Data for Infrared Measurement

Measurement ranges	see ordering data
Influencing variables	
- Drift	
With AUTOCAL	negligible
Without AUTOCAL	< 2% of smallest measurement range/week
- Temperature	max. 2% of smallest possible measurement range according to type plate per 10 K with an AUTOCAL cycle time of 3 h
- Atmospheric pressure	< 0.2% of measurement range per 1% change in pressure, corrected by internal pressure sensor
- Residual gases	Contact Buhler application specialist
- Electric - Voltage	< 0.1% of output signal span with a change of $\pm 10\%$
- Electric - Frequency	$\pm 2\%$ of full-scale value with a change in frequency of $\pm 5\%$
EM field 10 V/m, 80% amplitude modulation	
- 10 kHz to 500 MHz	1% of smallest possible measurement range
- 500 MHz to 1 GHz	2% of smallest possible measurement range
Display delay ( $T_{90}$ time)	dependent on dead time and selectable damping
Damping	adjustable from 0 to 99.9 s (electrical time constant)
Output signal noise	< $\pm 1\%$ of smallest possible measurement range (see type plate)
Display resolution	dependent on selected measurement range; selectable number of digits following decimal point
Output signal resolution	< 0.1% of output signal span
Characteristic	linearized
Linearization error	in largest measurement range: < 1% of full-scale value in smallest measurement range: < 2% of full-scale value
Repeatability	$\leq 1\%$ of smallest measurement range

## Technical Data for Oxygen Measurement

Measurement range	0 to 5% or 0, to 25% O <sub>2</sub> , programmable
Influencing variables	
- Drift	
With AUTOCAL	negligible
Without AUTOCAL	typical 1% O <sub>2</sub> / year in air
- Temperature	< 0.5% O <sub>2</sub> per 20 K, referred to a measured value at 68 °F
- Atmospheric pressure	< 0.2% measured value per 1% change in pressure
- Residual gases	residual gases containing heavy metals, H <sub>2</sub> S and halogens result in analyzer failures; O <sub>2</sub> concentrations < 0.5% are only permissible for a short time
O <sub>2</sub> error	on measurement of typical exhaust gases: < 0.05% O <sub>2</sub>
Output signal noise	< 0.5% of full-scale value
Response time ( $T_{90}$ -time)	dependent on dead time and selectable damping, but not < 30 s with a sample gas flow of approx. 1 l/min.
Display resolution	< 0.2% of full-scale value
Output signal resolution	< 0.2% of output signal span
Service life	approx. 2 years with 21% O <sub>2</sub>
Repeatability	$\leq 0.05\%$ O <sub>2</sub>